



# Community Redevelopment Advisory Board Regular Meeting

## Agenda

**May 22, 2025 @ 5:30 PM**

City Hall Commission Chambers  
401 S. Park Avenue

### welcome

Agendas and all backup material supporting each agenda item are accessible via the city's website at [cityofwinterpark.org/meetings](http://cityofwinterpark.org/meetings) and include virtual meeting instructions.

### assistance & appeals

Persons with disabilities needing assistance to participate in any of these proceedings should contact the City Clerk's Office ([407-599-3277](tel:407-599-3277)) at least 48 hours in advance of the meeting.

"If a person decides to appeal any decision made by the Board with respect to any matter considered at this hearing, a record of the proceedings is needed to ensure that a verbatim record of the proceedings is made, which record includes the testimony and evidence upon which the appeal is to be based." (F.S. 286.0105).

### please note

Times are projected and subject to change.

- 
- 1. Call to Order**
  - 2. Consent Agenda**
    - a. Approve the minutes of March 27, 2025 1 Minute
  - 3. Public Comments (for items not on the agenda): Three minutes allowed for each speaker**
  - 4. Action Items**
  - 5. Non-Action Items**
    - a. Update on Park Avenue refresh - Clarissa Howard 20 minutes
    - b. Public Works Capital Improvement Items - Charles Ramdatt 20 minutes
  - 6. Staff Updates**
    - a. Staff Updates 5 minutes
  - 7. Board Comments**
  - 8. Upcoming Agenda Items**
    - a. FY2026 Budget Planning Discussion 1 minute
  - 9. Adjournment**



Community  
Redevelopment  
Advisory Board

# agenda item 2.a

**item type**

Consent Agenda

**meeting date**

May 22, 2025

**prepared by**

**approved by**

Peter Moore, Director of Office of  
Management and Budget

**subject**

Approve the minutes of March 27, 2025

**motion | recommendation**

**background**

**alternatives | other considerations**

**fiscal impact**

**attachments**

1. CRAB-mins-2025-03-27 DRAFT



# Community Redevelopment Advisory Board Regular Meeting Minutes

March 27, 2025 at 5:30 PM

City Hall Commission Chambers  
401 S. Park Avenue

## Present

Carlos Benitez, Jay Trent, Pragasen Ramiah, Michael Perelman, Carl Creasman Jr

## Absent

Lindsay Eriksson

## Staff Present

Assistant Director of Economic Development and CRA Kyle Dudgeon, CRA Coordinator Anne Sallee, Director of Office of Management & Budget Peter Moore

### 1. Call to Order

The meeting was called to order at 5:30 p.m

### 2. Consent Agenda

- a. Approve the minutes of February 27, 2025

**Motion made by Mr. Trent to approve the minutes, seconded by Dr. Perelman.  
Motion carried unanimously with a 5-0 vote.**

### 3. Public Comments (for items not on the agenda)

### 4. Action Items

### 5. Non-Action Items

- a. Winter Park Enhancement Area (Brownfield) Program

Mr. Dudgeon provided an update of the Winter Park Enhancement area program through the city's Economic Development Advisory Board (EDAB). He covered background updates to the program, next steps, approvals and potential expectations moving forward. Florida Statute 163 (the statute that governs CRA's) and F.S. 376 (the statute that governs enhancement areas) have a strong correlation.

There may be opportunities for joint ventures with EDAB and programming incentives as Statute 376 is governed by the Florida Department of Economic Protection (FDEP). This department designates and approves these zones. The term "enhancement areas" is preferred over "brownfield areas". A map displaying all enhancement areas in the state was presented. Local jurisdictions can propose areas to the DEP. It is worth noting that one out of every two CRA's is also classified as a brownfield area.

Local benefits include state funding and grants, job creation incentives financed by the state, environmental assessments, cleanup initiatives, tax incentives, liability protections and various local programs. Several different types of programs under F.S. 376 can be utilized as enhancement areas overlaid with CRA, including loans, grants, permit waivers, payment amortization schedules and technical assistance. One noteworthy option is the transportation impact fee waivers and permit fee waivers outlined in F.S. 376.84 section 2.

Dr. Perelman inquired about the necessity of waiving permit fees. Mr. Dudgeon responded that waiving the 5% cost of the permit could support redevelopment efforts and address the time value associated with a project. Mr. Creasman offered an example of how permit fee waivers may be beneficial for affordable housing projects. Mr. Dudgeon indicated that the focus is predominantly on commercial projects, maybe including a multi-family development. Mr. Moore remarked that permit fees may represent as much as 16% of the overall project costs.

The enhancement area serves as a tool for planning specific types of development envisioned by the city for designated locations. To move forward, we need to complete three key steps: send a notice to all eligible property owners, notify FDEP about the area we wish to engage with and establish a resolution for commission approval. Last November, we held a work session with the city commission, who expressed their support for this initiative. We anticipate progressing with this project into the spring.

CRAB plays a crucial role when specific elements or incentives require fiscal accommodation. Given the significant relationship between enhancement areas and the CRA, a presentation will be given to the board for consideration in such situations.

Mr. Ramiah inquired about how this program will assist current property owners. Mr. Dudgeon explained that with any form of redevelopment, we can offer grants, permit waivers, and property cleanup to alleviate the liability for property owners. However, Dr. Perelman opposes the idea of removing liability from property owners.

Mr. Benitez inquired whether specific enhancement areas have been identified for targeting or if the goal is simply to be available and offer alternatives. Mr. Dudgeon responded that they will provide eligibility information, and interested individuals would need to go through a separate programmatic process. This would involve discussions about incentives and any necessary liability considerations, which require city commission approval. Funding will be determined on a case-by-case basis, and grants will be reviewed by staff before being approved by the commission.

Mr. Creasman summarized that the projects the CRA is engaged in may present an opportunity to access state funding to support its initiatives. Moreover, if new concepts emerge, there may be an opportunity to explore the enhancement area funds. Mr. Benitez suggested looking into the Denning/Fairbanks sinkhole area and the site designated for new commercial property, where the installation of a drainage ditch is needed. Both locations could be identified as enhancement areas.

b. MLK Community Playground Improvements

At the fourth community meeting, the overall feedback was positive, with recommendations that primarily focused on materials and finishes, such as those used for the playground structures and surfaces, connectivity to the adjacent residential area across Denning, and adjustments to the placement of some play structures. The project has been community-focused from the beginning.

Dix Hite's work was to create a playground conceptual plan, which informed the solicitation for a construction contract. The team included Ovation Construction, Foster Conant (Landscape Architect), and Miller Recreation Equipment. There should be no significant design changes now, only a progression in detail from conceptual to 50% drawings to final construction drawings.

Next steps involve finalizing the construction documents to 100%. Staff will review them with the Commission in Spring, aiming for construction to tentatively start in mid-to-late summer. The build is expected to last about 7-9 months, influenced by material and labor lead times. Completion times may vary as the process is still early. An additional community meeting, designated as Meeting Number 5, will be held. The project will subsequently return to CRAB, the Parks Board, and thereafter be presented to the City Commission.

Approximately 30 individuals attended the community meeting. The staff will distribute the geographic map following the fifth meeting. As part of the parking enhancements, there will be an increase of approximately 25 additional spaces and this will include an agreement with Valencia for expanded parking options.

**6. Staff Updates**

a. Staff Updates

Mr. Dudgeon provided a list of current projects in the packet, with particular emphasis on the Lake Rose property. He has begun to integrate several ideas proposed by the board into the project's vision. A session with the relevant departments is scheduled for April 15. Additionally, a proposal for a dock was mentioned. Austin's lease is set to conclude in August, and the development of the Lake Rose project will occur in phases.

b. CRA Annual Report FY24

Hard copies of the CRA Annual Report for FY24 were distributed to the board members..

c. Board Appointment Update

Mr. Trent was advised to submit a new application if he wishes to be reappointed. There is currently a vacancy for seat 4.

**7. Board Comments**

Dr. Perelman requested an update on Unity Corner. We are currently waiting for a date from the foundry.

Mr. Trent praised Mr. Ramiah for his leadership role in the Taste of Hannibal Square. He also acknowledged Mr. Benitez, the executive director of the Saint Peter Claver Prison Ministry. Mr. Benitez was humbled by the compliments, and both men expressed their gratitude. Unfortunately, the audio was not heard when Mr. Ramiah invited the staff to greet his group.

#### **8. Upcoming Agenda Items**

Mr. Dudgeon will be absent for the April and May meetings. Mr. Moore and Ms. Sallee will be working with the board on agenda items.

#### **9. Adjournment**

The meeting adjourned at 6:15 p.m.

Approved by the board on  
/s/ Bahiyyah Layton, Board Coordinator



# Community Redevelopment Advisory Board

# agenda item 5.a

**item type**

Non-Action Items

**meeting date**

May 22, 2025

**prepared by**

Kyle Dudgeon, Assistant Division Director of Economic Development/CRA

**approved by**

Peter Moore, Director of Office of Management and Budget

**subject**

Update on Park Avenue refresh - Clarissa Howard

**motion | recommendation**

N/A

**background**

Approved as part of the FY25 budget, staff has been working with a consultant on improvements to the Park Avenue area designated as the 'Park Avenue refresh'. As noted in the attached staff report, it includes replacement of all streetlights in the project area. It also considers several other elements as part of a multi-phase effort for downtown core reinvestment.

Staff is providing an update on this effort.

**alternatives | other considerations****fiscal impact**

Existing impacts have been provided for in the budget. Other project phases and costs are still under review and will be updated along with the FY26 budget.

**attachments**

1. Park Ave Refresh Staff Report\_April 2025
2. park-avenue-refresh-regular-meeting-presentation-2025-04-23
3. CONCEPT - Updated Landreth - Sternberg streetlight poles 04.17.25

**item type**

Action Items Requiring Discussion

**meeting date**

April 23, 2025

**prepared by**

Clarissa Howard, Director of Communications

**approved by**

Randy Knight, City Manager

**subject**

Park Avenue Refresh streetlight pole design and purchase approval

**motion | recommendation**

Approval of streetlight design and purchase

**background**

At the [February 26, 2025, City Commission meeting](#), approval was given for the [Park Ave Refresh](#) project design, which included the replacement of all streetlights in the project area: Park Avenue between Fairbanks and Webster avenues. This agenda item is seeking approval of the design and the funding for the new streetlights for the entire project with the ability to order the lights on an as-needed basis, depending on the phase of the project under construction.

The current streetlights are 26 years old, purchased in 1999 when Park Avenue was originally bricked. They are not only antiquated, they are also internally filled with a variety of unnecessary cords and tubing that have been used for many purposes over the years, have become unreliable in some areas, and use an outdated light fixture. Replacing all the streetlights with a new decorative, multi-channel and multi-use pole that is smart city compatible, and dark sky fixtures has substantial benefits:

- Enhances the safety of Park Avenue by improving lighting and visibility.
- Reduces lighting impact to nearby residences and maximizes light array on the streets and sidewalks where it is needed and most impactful.
- Prevents light from escaping upward and outward, therefore reducing light pollution.
- Not only do the lights enhance aesthetics, they are also energy efficient, using LED bulbs that are more cost-efficient to operate.

The new pole design offers:

- Dark sky light with decorative finial
- Two smart device attachments (antenna, camera and/or speaker)
- GFI outlets at top of pole and at the base
- Banner arm or wreath connection
- Double hanging planters
- Integrated smart hub
- Decorative pedestal

An entirely new electrical plan will also be incorporated into the Park Avenue Refresh project which will reduce streetlight outages experienced in the past and provide a more efficient and reliable system to support electrical needs for events and holiday lighting.

## Park Avenue Refresh - Lighting

---



\_\_\_\_\_

DARK SKY LIGHT WITH DECORATIVE FINIAL

\_\_\_\_\_

TWO (2) SMART DEVICES & GFI OUTLET

\_\_\_\_\_

BANNER ARM OR WREATH CONNECTION

DOUBLE HANGING PLANTERS

INTEGRATED SMART HUB

\_\_\_\_\_

GFI OUTLET AT BASE

DECORATIVE PEDESTAL

\_\_\_\_\_

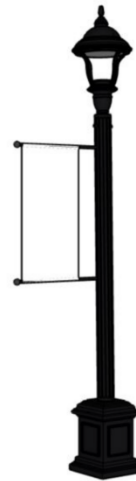

\_\_\_\_\_

DARK SKY LIGHT WITH DECORATIVE FINIAL

\_\_\_\_\_

BANNER ARM OR WREATH CONNECTION

\_\_\_\_\_

DECORATIVE PEDESTAL

\_\_\_\_\_



### alternatives | other considerations

Keep current streetlights and only replace as needed.

### fiscal impact

Sternberg streetlight costs:

Unit Cost	Quantity	Total
\$9,310	~100	\$931,000

Payment of streetlights would be incurred during the associated phase:

Phase	Approx. # of streetlights	Approx. cost per phase
Phase 1	34	\$316,540
Phase 2	38	\$353,780
Phase 3	24	\$223,440

## **attachments**

1. QUOTE - Updated Landreth - Sternberg streetlight poles
2. CONCEPT - Updated Landreth - Sternberg streetlight poles 04.17.25



# City of Winter Park

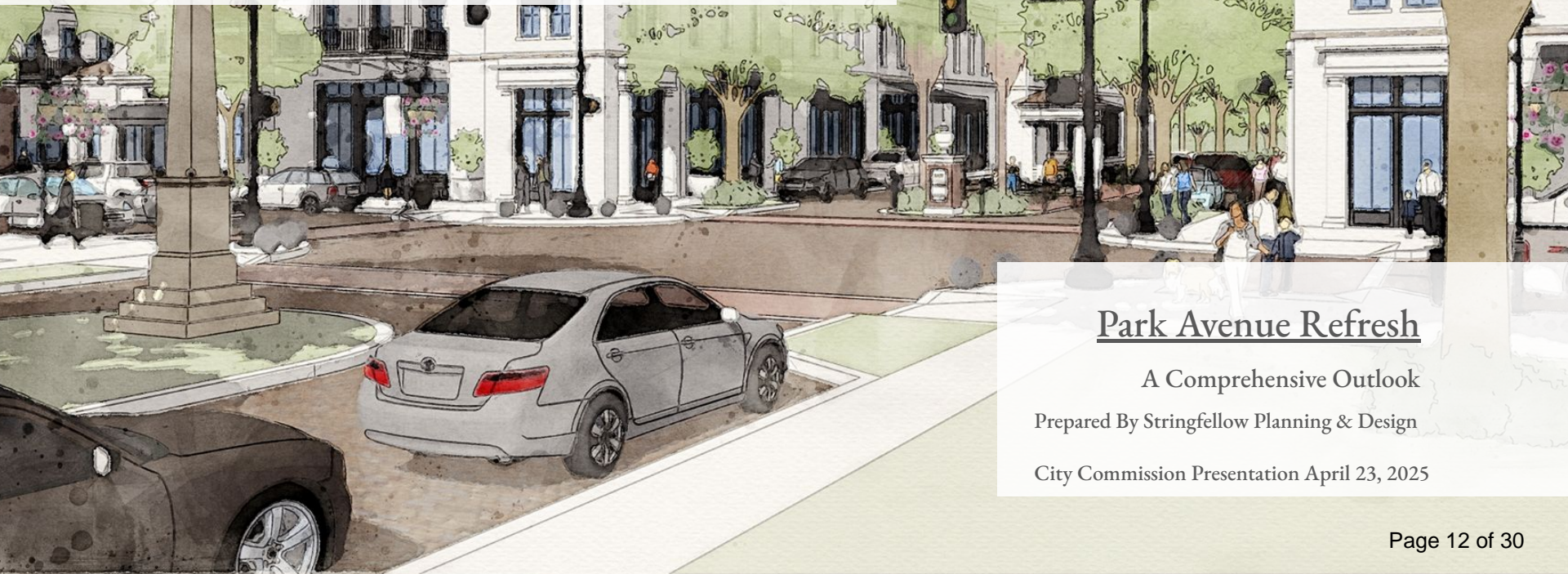

## Park Avenue Refresh

A Comprehensive Outlook

Prepared By Stringfellow Planning & Design

City Commission Presentation April 23, 2025

# Lighting Approval

Receive approval for the proposed Park Avenue Streetlight Design & Purchase



# Project Update

## Ongoing Efforts

1. Survey Complete on April 11th
2. Phase 1 Budget Schematic
3. Installation of Gateways expected to begin the week of May 26th with dedication
4. Mobility Hub approved on April 9th with launch expected with Gateways in June
5. Light Design Complete
6. Contractor and Consultant Site Walk

# Phase 1 - Garfield to Canton

## Garfield - Canton

1. Replace/Repair two damaged raised planter bed N of Garfield.
2. Bulb out/curb extension into Park Ave from Garfield. Install Bollards for safety.
3. New Electrical, Low Voltage, Irrigation.
4. Remove Crepe/Palm Tree/Elm and replace with Live Oaks.
5. New Oak Trees have root barriers, tree grate properly installed, irrigation and coordinate with light locations.
6. Air Spade tree planters, add quality soil and plant 3-4 inch groundcover with irrigation.
7. Replacement of trash cans, pots, etc
8. Updated light poles and accessories.
9. Assess on street drainage issues.

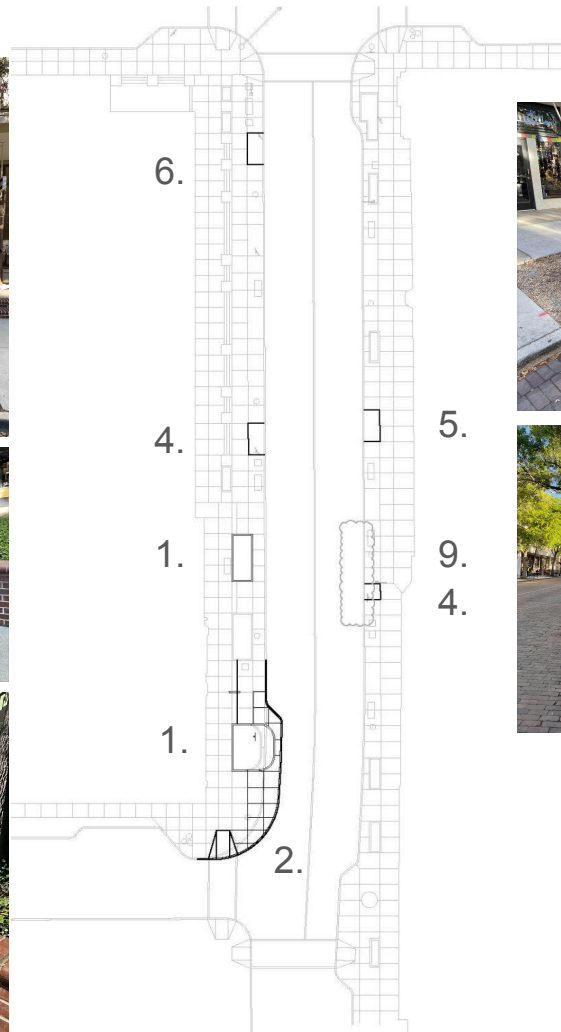

## Phase 1 - Canton to Cole

1. Replace/Repair two damaged raised planter beds.
2. Bulb out into Park Ave at mid block to protect vehicles and raised brick planter.
3. New Electrical, Low Voltage, Irrigation.
4. Updated light poles and accessories.
5. Remove non-shade trees.
6. Patch/replace concrete where designated.
7. New Live Oak Trees with root barriers, tree grate properly installed, irrigation and coordinated with light locations.
8. Air Spade tree planters, add quality soil and plant 3-4 inch ground cover plants with irrigation.
9. Replacement of trash cans, pots, etc
10. Eliminate non-required signage.

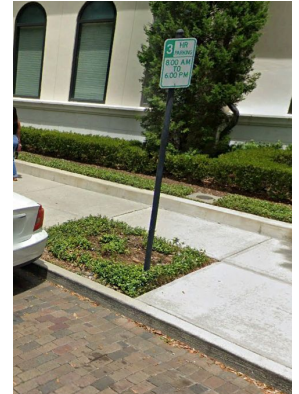
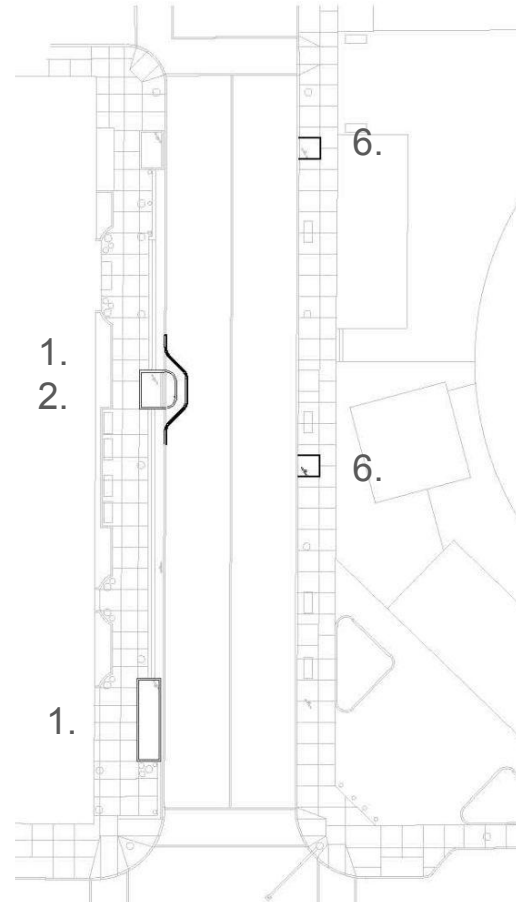

## Phase 1 - Cole to Swoope

1. New Electrical, Low Voltage, Irrigation.
2. Updated light poles and accessories.
3. Remove non-shade trees.
4. New Live Oak Trees with root barriers, tree grate properly installed, irrigation and coordinated with light locations.
5. Air Spade tree planters, add quality soil and plant 3-4 inch ground cover plants with irrigation.
6. Patch/replace concrete where designated.
7. Replacement of trash cans, pots, etc.
8. Eliminate non-required signage.
9. Assess on street drainage issues.

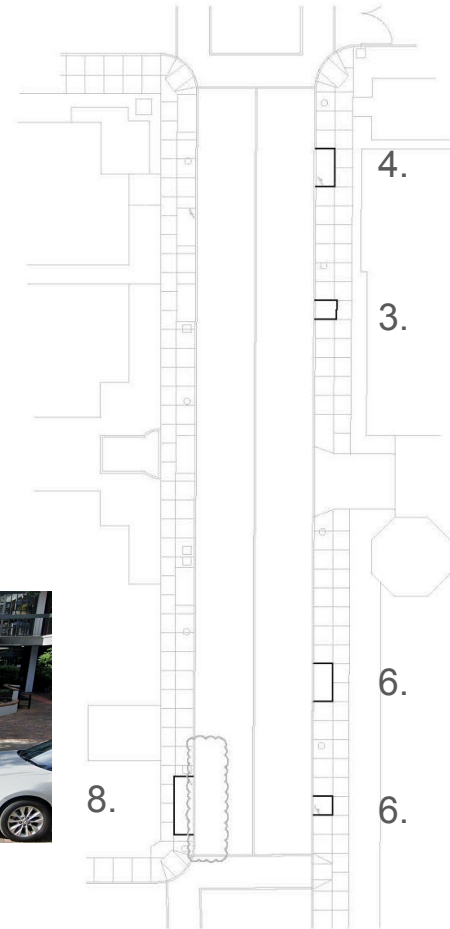



# Lighting Approval

Unit Cost	Quantity	Total
\$9,310.00	~100	\$931,000.00



Phase 1	Webster to Canton	~34	~\$316,540
Phase 2	Canton to New England	~38	~\$353,780
Phase 3	New England to Fairbanks	~24	~\$223,440

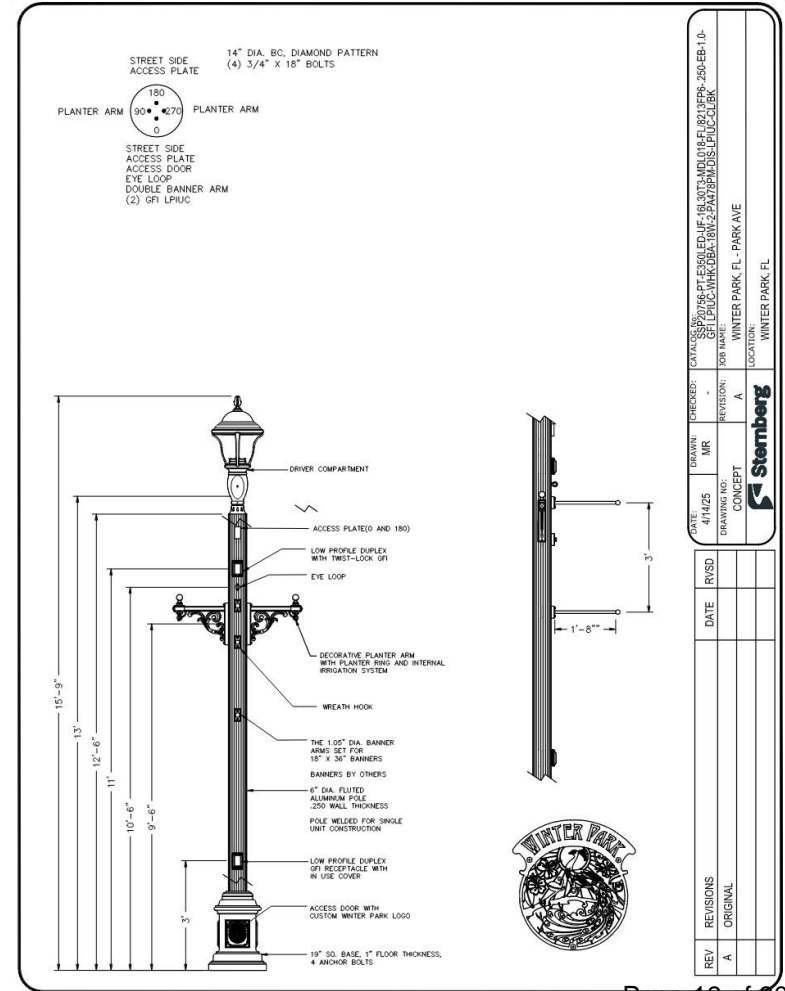

# Request

Approval of Sternberg streetlight design and purchase plan, as presented.

STREET SIDE  
ACCESS PLATE

14" DIA. BC, DIAMOND PATTERN  
(4) 3/4" X 18" BOLTS

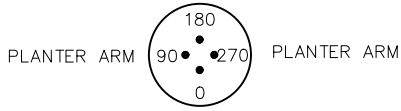

STREET SIDE  
ACCESS PLATE  
ACCESS DOOR  
EYE LOOP  
DOUBLE BANNER ARM  
(2) GFI LPIUC

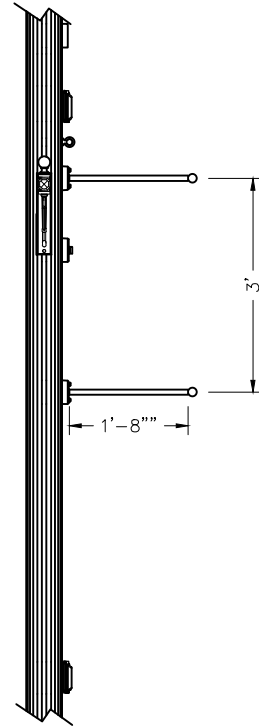
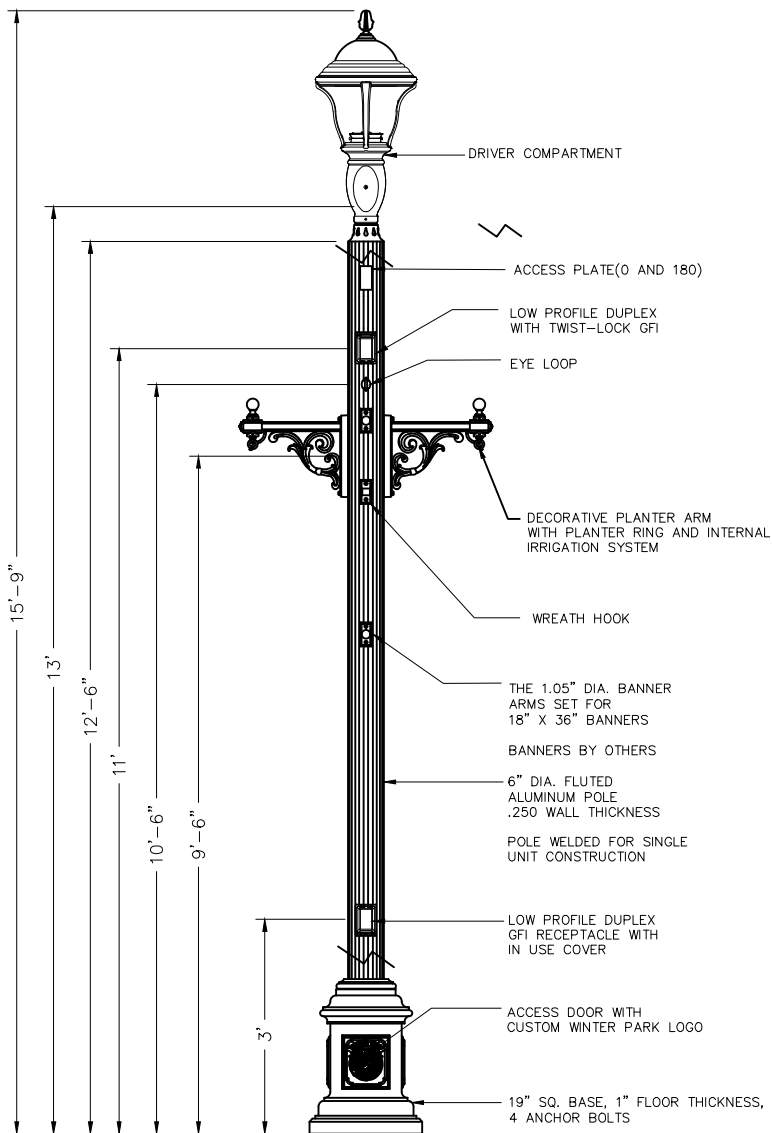

DATE:	4/14/25	DRAWN:	MR	CHECKED:	-	CATALOG NO.:	SSP20756-PT-E350LED-UJ-16L30T3-MD1018-FLJ8213FP6-250-EB-1.0-GFI LPIUC-WHK-DBA-18W-2-PA478PM-DIS-LPIUC-CLBK
DRAWING NO.:	CONCEPT	REVISION:	A	JOB NAME:	WINTER PARK, FL - PARK AVE	LOCATION:	WINTER PARK, FL

REV	REVISIONS	DATE	RVSD
A	ORIGINAL		





# Community Redevelopment Advisory Board

# agenda item 5.b

**item type**

Non-Action Items

**meeting date**

May 22, 2025

**prepared by**

Kyle Dudgeon, Assistant Division Director of Economic Development/CRA

**approved by**

Peter Moore, Director of Office of Management and Budget

**subject**

Public Works Capital Improvement Items - Charles Ramdatt

**motion | recommendation**

N/A

**background**

Staff will be providing an update on capital investment related to ongoing/existing projects as well as considerations for FY26. Of note:

Killarney Phase I - Construction underway with approved existing budget by the Agency in February 2025.

Killarney Phase II - Scope procured and under evaluation. Funds would be used under the CRA's existing budget for W. Fairbanks drainage improvements. From an efficiency perspective, staff has been requested to consider Phase II prior to any bricking which has already been approved by the agency. Phase II is estimated at \$1.216 million.

MLK Design Phase I - Initiated. Proposed improvements would be considered under existing funds for a new hydraulic connection from MLK to Lake Rose and is consistent with previous study efforts to connect these two water bodies for stormwater mitigation purposes.

**alternatives | other considerations****fiscal impact**

## **attachments**

1. Killarney Dr Phasing Exhibit





# Community Redevelopment Advisory Board

# agenda item 6.a

## item type

Staff Updates

## meeting date

May 22, 2025

## prepared by

Kyle Dudgeon, Assistant Division Director of Economic Development/CRA

## approved by

Peter Moore, Director of Office of Management and Budget

## subject

Staff Updates

## motion | recommendation

N/A

## background

**(1) Denning/Fairbanks Improvements** - Staff has been requested to review the northwest corner of the Denning/Fairbanks intersection, and has engaged with a consultant on concepts for potential improvements on the CRA's purchased lots. Staff met with the consultant last month for direction and are currently developing concepts for consideration. This is anticipated to be a multi-month process.

**(2) MLK Park Unity Corner** - The Dr. King sculpture is currently in Sanford and still under development. Staff anticipates a review of the work product with the requesting community group in late May/early June with installation occurring soon after in early summer.

**(3) MLK Park Community Playground** - Design schematic and construction documents continue to be underway. Staff is anticipating a fifth and final public meeting for revisions prior to review and approval by the city's Agency/Commission.

**(4) CRA Stormwater Improvement/W. Fairbanks Stormwater Improvements** – The CRA Agency approved a Lake Killarney outfall project in February which is expected to provide immediate relief for storm conveyance. Notification has been sent to the neighborhood, construction is imminent, and conclusion is expected in late summer. Attached is a copy of the notification. Staff is also coordinating with Orange County on timing of additional large scale stormwater benefits to the area. This begins with a detailed study. These efforts are currently underway and will be reviewed by the board when complete.

**(5) Park Avenue Gateway Arches** - Fabrication is in its concluding phase. Installation is expected early summer beginning with the north end first and then south.

**(6) West Meadow Public Facility (Public restrooms)** – Construction of the project is underway, and is expected to continue through the summer and fall.

**(7) Knowles Avenue Parking Enhancements** - Approved as part of the FY25 budget, the

Knowles Ave project assists with hardscape issues, reforming the dismantling of curbs from tree roots, signage, repainting parking spaces, and stormwater enhancements. This project is expected to begin next month.

**(8) Misc.** – Videographer has been capturing reel on several CRA projects and initiatives including the facade program, work on W. Fairbanks, and SYEP. New content is expected in summer 2025.

## **alternatives | other considerations**

## **fiscal impact**

## **attachments**

1. Construction notice - Killarney

## **Construction Notice City of Winter Park**

The Public works Department will be Upgrading the Drainage System, replacing Curb, and improving the brick road at Killarney drive between Lakeview Ave and Shoreview Ave, Work is scheduled to begin Monday, May 19, at 7 a.m., and is anticipated to be completed by Monday, June 28, by 5 p.m. (**weather permitting**). Expect temporary lane and road Closures. Detours will be set up to route traffic around the construction zone.

We regret any inconvenience caused by this project and appreciate your patience. Should you have any questions or require special consideration, please contact 407-599-3523.

---

Ramone Medwinter  
Project Coordinator  
Public Works & Transportation Department  
[rmedwinter@cityofwinterpark.org](mailto:rmedwinter@cityofwinterpark.org)



# Community Redevelopment Advisory Board

# agenda item 8.a

**item type**

Upcoming Agenda Items

**meeting date**

May 22, 2025

**prepared by**

Kyle Dudgeon, Assistant Division Director of Economic Development/CRA

**approved by**

Peter Moore, Director of Office of Management and Budget

**subject**

FY2026 Budget Planning Discussion

**motion | recommendation**

N/A Discussion and goal setting only.

**background**

Staff is developing the FY26 budget and has included the FY25 proforma and Capital Plan for reference. Staff receives the preliminary estimates of taxable value which determines the CRA's funding for the following fiscal year at the end of May, early June. Those final numbers will be used to present a proposed budget to the CRA AB at the June meeting so that budget recommendations can be made. At this point, new funding will only come from revenue growth estimates that exceed last year's estimates, or by re-appropriating funding from existing items in the CIP.

**alternatives | other considerations****fiscal impact****attachments**

1. Ten Year Pro-Forma - FY 2025 CRA Extension CRA AB May 2025

## Community Redevelopment Agency 5-Year CIP

	FY 2025	FY 2026	FY 2027	FY 2028	FY 2029
<b>ESTIMATED REVENUES</b>					
TIF Revenue - City	4,872,398	5,164,742	5,371,332	5,478,758	5,643,121
TIF Revenue - County	3,840,034	4,070,436	4,233,253	4,317,919	4,447,456
Investment Earnings	427,913	427,913	427,913	385,122	346,610
Misc. Revenues	30,000	30,000	-	-	-
CRA Revenues	9,170,345	9,693,091	10,032,498	10,181,798	10,437,187
Fund Balance	-	-	-	-	-
<b>Total Revenues</b>	9,170,345	9,693,091	10,032,498	10,181,798	10,437,187
<b>ESTIMATED EXPENDITURES</b>					
Personnel & Indirect Costs	841,165	881,777	919,411	950,750	983,254
General Operating	765,745	787,560	783,492	806,991	831,195
Community Initiatives	1,019,000	1,440,360	1,483,186	1,523,452	1,564,926
Capital Maintenance	150,000	156,000	161,460	166,304	171,293
Misc. Capital Enhancements	140,000	300,000	309,000	318,270	327,818
Debt Service & Transfers	1,066,442	710,568	-	-	-
<b>Total Expenditures</b>	3,982,352	4,276,266	3,656,550	3,765,767	3,878,486
<b>Annual Surplus/Deficit</b> (Funding Available for Additional Projects and Programs)	5,187,993	5,416,825	6,375,948	6,416,031	6,558,700

<b>Five Year CIP Project Balance Reallocation and Reprioritization</b>	<b>Prj. Bal.</b>	<b>FY 2025</b>	<b>FY 2026</b>	<b>FY 2027</b>	<b>FY 2028</b>	<b>FY 2029</b>
Misc. Infrastructure Improvements	426,498	1,200,000	500,000			
17/92 Streetscape					5,000,000	5,000,000
New York Streetscape	150,000					
Bollards in Central Business District	73,848					
MLK Basin Stormwater Improvements	1,500,000	1,500,000	2,000,000			
Denning/Fairbanks Intersection Improvements	4,500,000					
West Meadow Restroom & Pavillion	1,200,000					
MLK Park Improvements	5,113,210					
W. Fairbanks Stormwater/Infrastructure	2,000,000	1,000,000	2,000,000			
MLK Surface Parking	1,200,000					
Canton Ave Stormwater Drainage			1,300,000	3,450,000		
1792/Fairbanks Intersection Improvements				2,000,000	2,000,000	
Killarney Estates Brick & Drainage Refresh		500,000				
Park Ave Refresh		1,000,000				
<b>CRA Project Funding Total</b>	<b>16,163,556</b>	<b>5,200,000</b>	<b>5,800,000</b>	<b>5,450,000</b>	<b>7,000,000</b>	<b>5,000,000</b>
<b>Fund Surplus/Deficit</b>		<b>(12,007)</b>	<b>(383,175)</b>	<b>925,948</b>	<b>(583,969)</b>	<b>1,558,700</b>
<b>Cumulative Fund Balance (Reserves)</b>	<b>422,983</b>	<b>410,976</b>	<b>27,801</b>	<b>953,749</b>	<b>369,781</b>	<b>1,928,481</b>